

Hardware and Parts

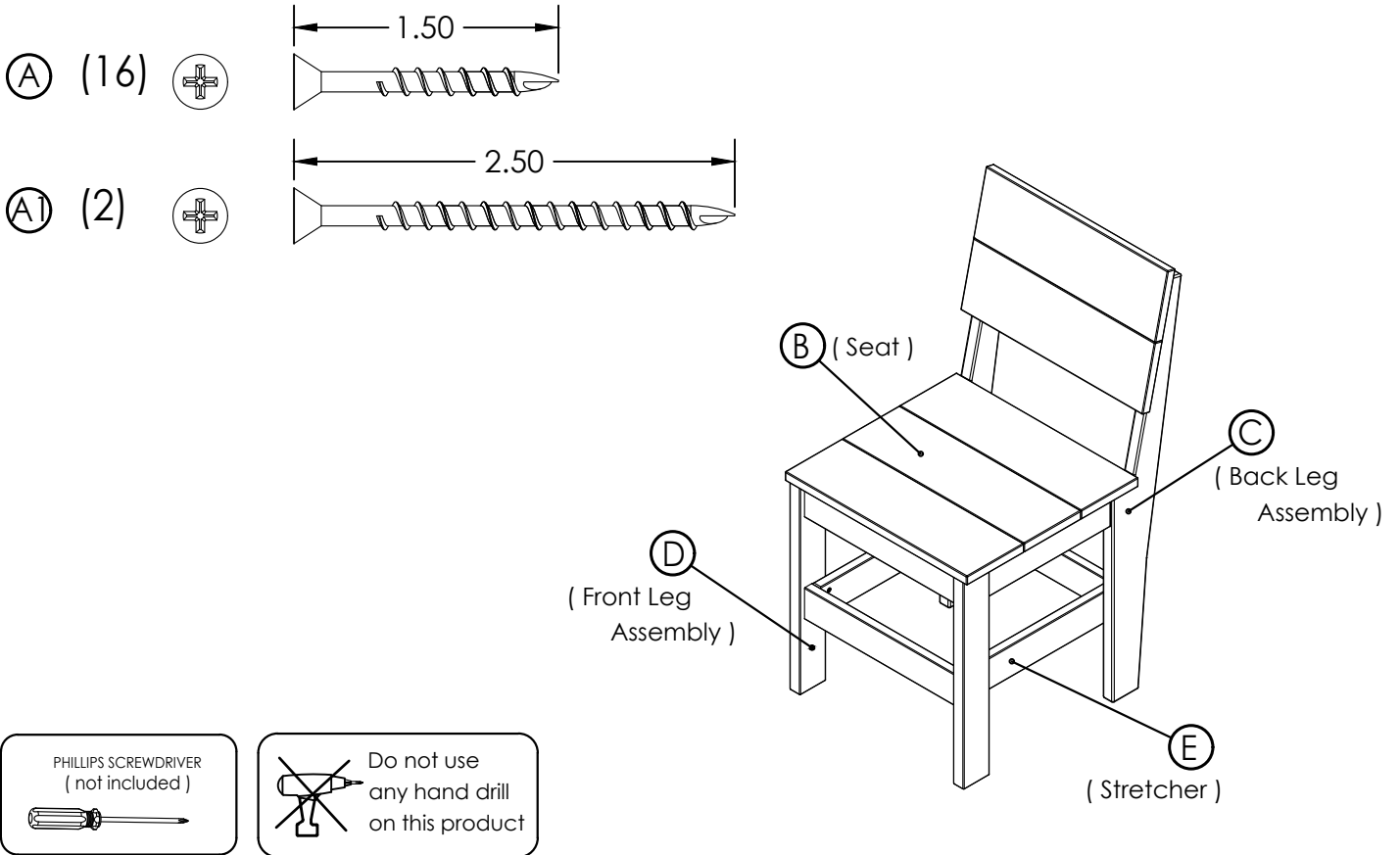

Figure 1

1- After laying out all components, position the Seat (B) upside-down and align the Back Leg Assembly (C) with the Seat Supports, as shown below. Insert a Screw (A) through a Seat Support into a predrilled hole and begin to tighten the screw with a screwdriver. Once the screw is a few turns tightened, move on to another screw until all 4 have been started. With the Seat loosely attached to the Back Leg, use Screw (A1) to attach the Leg Support to the Seat. With this 5th screw tight, finish tightening the first 4 screws into the Legs.

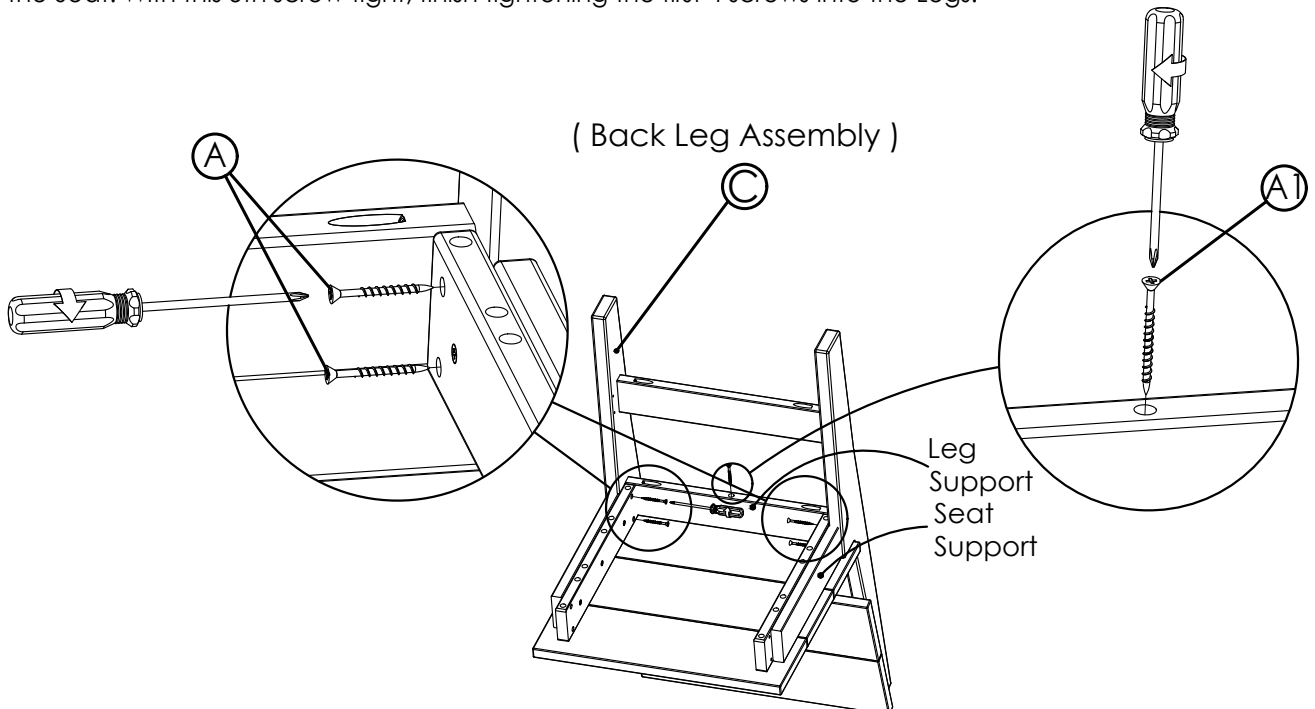

Figure 2

2 - Repeat Step 1 for the Front Leg Assembly (D). First by starting the Screws (A) in the Seat Support. Then, driving the Screw (A1) to hold the Leg Support in place. And finally, tightening the screws in the Seat Support.

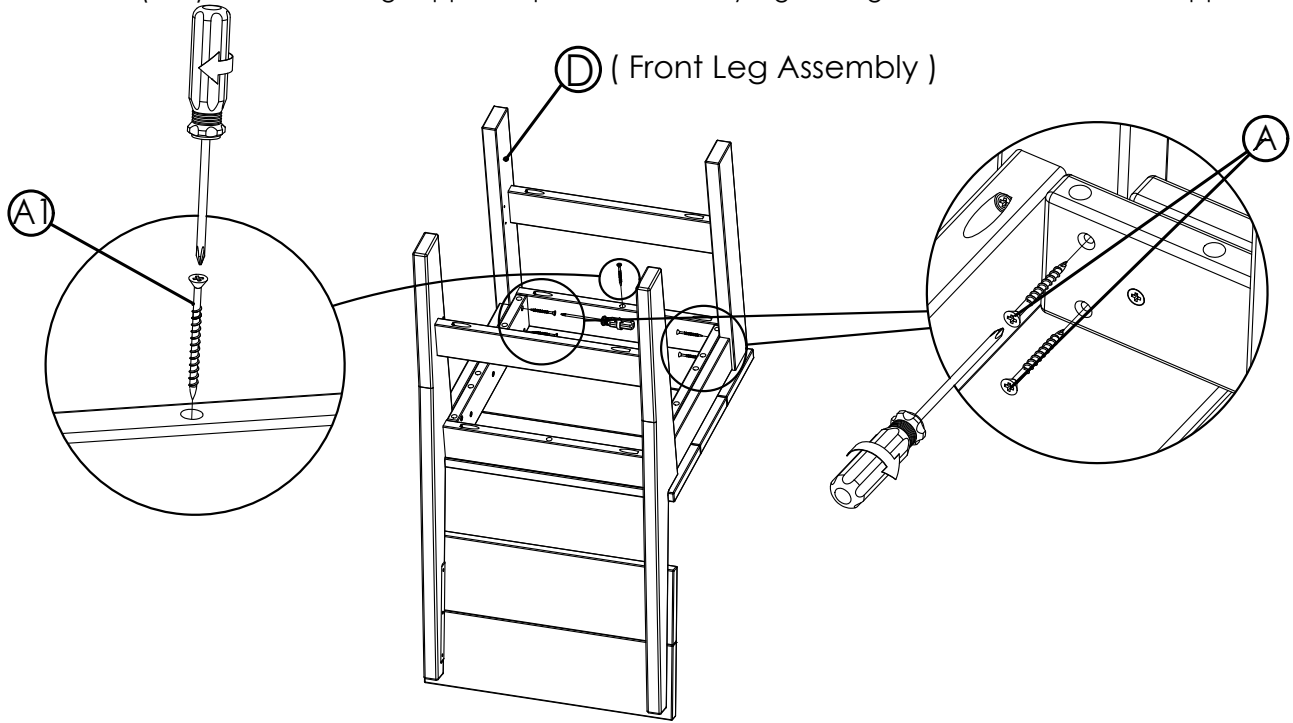
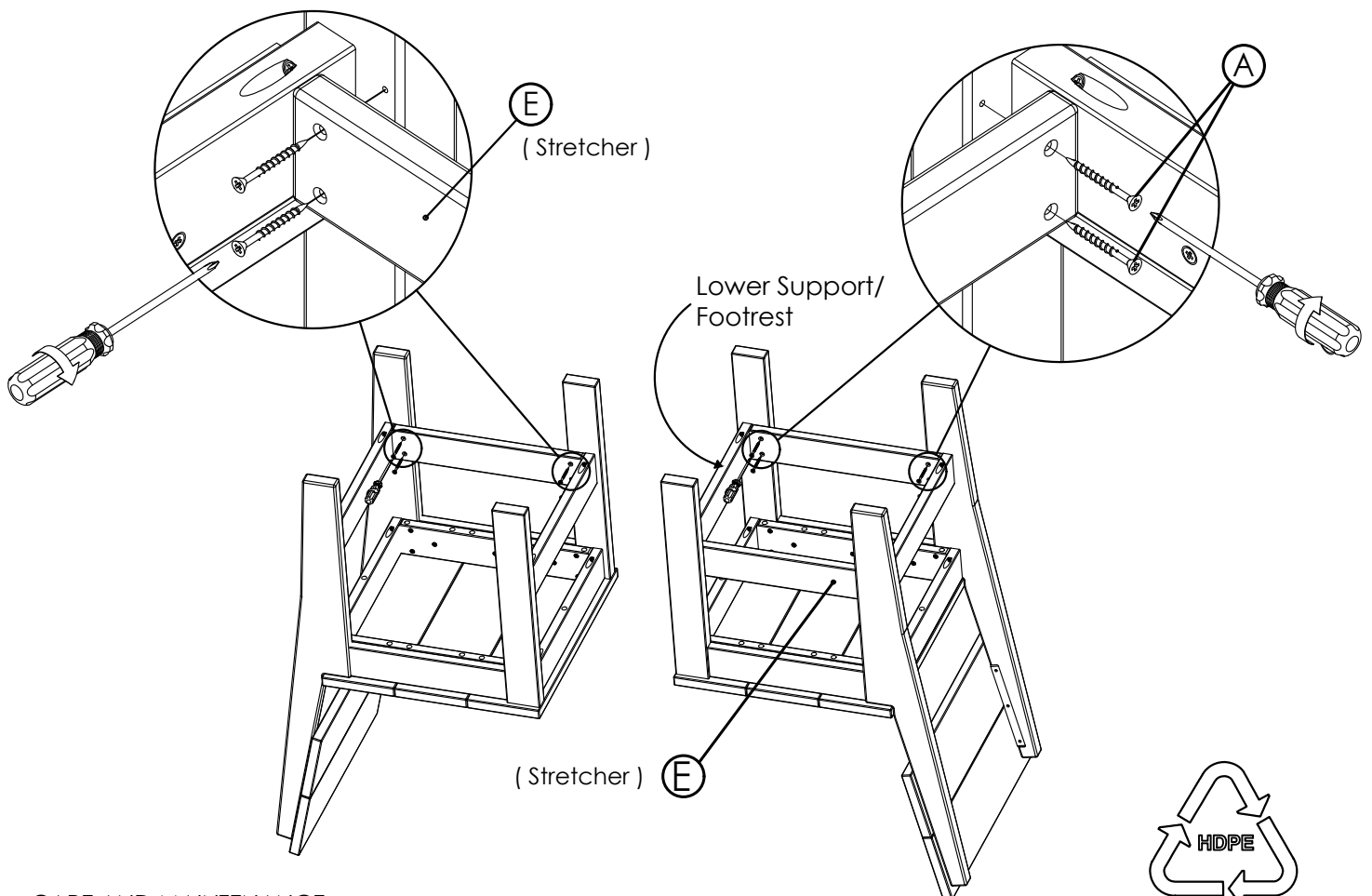

Figure 3

3 - Finalize the assembly of bench by attaching the 2 Stretchers (E). Starting on either side, align the Stretcher with the predrilled holes on the inside of each Leg (at the same height as the Lower Support on the Dining Height Chair or the Footrest on the Bar Height Chair) and, as we did in the previous steps, insert a Screw (A) through the hole and tighten it a few turns. Repeat this for all four screws, attaching the Front and Back Legs. Before tightening, attach both Stretchers. With both Stretchers in place, finish tightening all 8 screws.



CARE AND MAINTENANCE

To clean your product, use mild soap and water. For heavy soil build-ups use any non-abrasive household cleaners or ask your Sales Representative about Sister Bay Furniture Cleaner.

Please contact our Customer Service Department for assembly assistance, questions or replacement parts at 1-866-947-7632 or email info@sisterbayfurniture.com. Our Customer Service Department is available Monday - Friday from 8:30 a.m. to 4:30 p.m. EST

